



atelier

Atelier è configurabile utilizzando moduli in acciaio con sezione minima di 10x10mm e contenitori in legno con diverse tipologie di aperture. Telai e contenitori possono essere sovrapposti e affiancati a piacimento, posizionati su basi o sospesi a parete. Sono disponibili accessori da inserire all'interno dei telai e top in HPL o marmo.

Atelier can be configured using modular elements in steel with a minimum 10x10mm cross-section as well as wooden containers with several different types of openings. Both frames and containers can be stacked and placed side by side as desired, either installed onto support bases or wall-mounted. Accessories to be integrated into the HPL or marble frames and tops.

Atelier peut être configuré en utilisant des modules en acier avec une section minimum de 10x10 mm et des bacs en bois avec plusieurs typologies d'ouvertures. Châssis et bacs peuvent être superposés et associés à loisir, positionnés sur des bases ou suspendus au mur. Des accessoires sont disponibles pour l'insertion à l'intérieur des châssis et plateau en HPL ou marbre.

Bei der modularen Serie Atelier lassen sich Stahlmodule mit einer Mindeststärke von 10x10 mm mit Holzbehältern verschiedener Arten und Öffnungen kombinieren. Gestelle und Behälter können übereinander oder nebeneinander angeordnet, auf einen Unterbau gestellt oder an der Wand aufgehängt werden. Verschiedene Einsätze für die Gestelle sowie Abschlussplatten aus HPL oder Marmor als Zubehör erhältlich.

Atelier se puede configurar utilizando módulos de acero con sección mínima de 10x10mm, así como contenedores de madera con distintos tipos de aperturas. Bastidores y contenedores, pueden colocarse uno encima del otro o uno al lado del otro, según se prefiera, posicionados sobre bases o colgados en la pared. Están disponibles accesorios que se pueden introducir en el interior de los bastidores y encimeras de laminado de alta presión (HPL) o mármol.



materiali / materials



acciaio
steel
acier
Stahl
acero



HPL

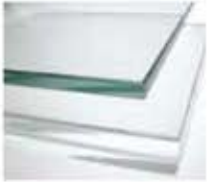

vetro
glass
verre
Glas
cristal



MDF
DM



Le materie prime che costituiscono il sistema atelier derivano da un processo di riutilizzo e sono a loro volta riciclabili.

The primary materials used in the system atelier are sourced from a reuse process, and are in turn recyclable.

Les matières premières qui composent le système atelier dérivent d'un processus de réutilisation et sont à leur tour recyclables.

Die Rohstoffe für das System atelier entstammen einem Wiederverwertungsprozess und sind Ihrerseits wiederum recyclebar.

Las materias primas que constituyen el sistema atelier proceden de un proceso de reutilización y son, a su vez, reciclables.



finiture / finishes

telaio / structure / châssis / Gestell / bastidor

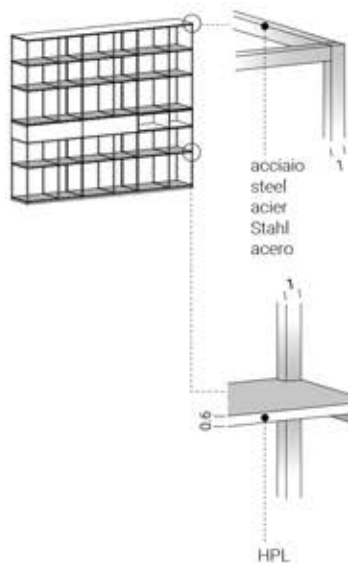

verniciatura a polveri
powder coating
peinture en poudres
Pulverlackierung
pintura en polvo

- C12** bianco white
- C21** seta silk
- C23** corda ecru
- C30** ghisa cast-iron
- C14** antracite anthracite

- C08** nero black
- C29** bronzo bronze

laccato
lacquered
laqué
lackiert
lacado

- Q05** bianco white
- Q16** seta silk
- Q17** corda ecru
- Q20** ghisa cast-iron
- Q14** antracite anthracite

essenze
woods
bois
Holzes
maderas

- Q04** nero black
- Q21** bronzo bronze
- Y37** rovere affumicato smoked oak
- Y38** rovere nero black oak

dimensioni / dimensions

telaio / structure / châssis / Gestell / bastidor

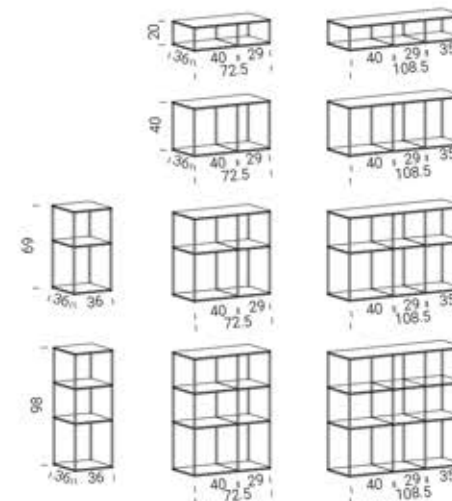

contenitori / cabinets / modules de rangement / Behälter / contenedores

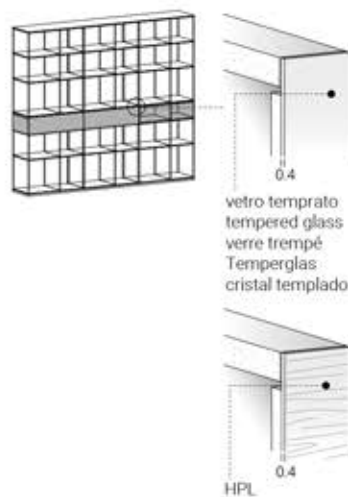

laccato
lacquered
laqué
lackiert
lacado

- Q05** bianco white
- Q16** seta silk
- Q17** corda ecru
- Q20** ghisa cast-iron
- Q14** antracite anthracite

- Q04** nero black
- Q21** bronzo bronze

essenze
woods
bois
Holzes
maderas

- Y37** rovere affumicato smoked oak
- Y38** rovere nero black oak

contenitori / cabinets / modules de rangement / Behälter / contenedores

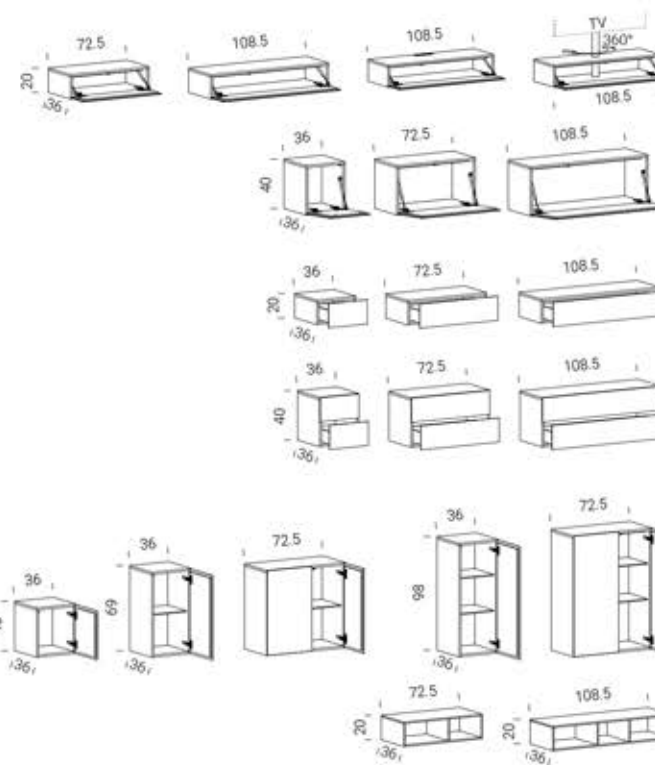

moduli interni / internal modules / modules internes / interne Module / módulos internos

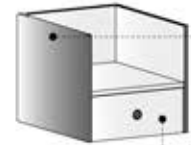

A acciaio
steel
acier
Stahl
acero

B MDF

A verniciatura a polveri
powder coating
peinture en poudres
Pulverlackierung
pintura en polvo

	C12 bianco white
	C21 seta silk
	C23 corda ecru
	C30 ghisa cast-iron
	C14 antracite anthracite
	C08 nero black
	C29 bronzo bronze

B laccato
lacquered
laqué
lackiert
lacado

	Q05 bianco white
	Q16 seta silk
	Q17 corda ecru
	Q20 ghisa cast-iron
	Q14 antracite anthracite
	Q04 nero black
	Q21 bronzo bronze

essenze
woods
bois
Holzes
maderas

	Y37 rovere affumicato smoked oak
	Y38 rovere nero black oak

piano / top / plateau / platte / sobre



marmo
marble
marbre
Marmor
mármol



HPL

marmo/marble
marbre/Marmor
mármol

	Z01 bianco Carrara white Carrara
--	--

	Z02 nero Marquifa black Marquifa
--	--

HPL

	L03 bianco white
	L08 grigio Londra London grey
	L06 nero black

laccato
lacquered
laqué
lackiert
lacado

	Q05 bianco white
	Q16 seta silk
	Q17 corda ecru
	Q20 ghisa cast-iron
	Q14 antracite anthracite
	Q04 nero black
	Q21 bronzo bronze

essenze
woods
bois
Holzes
maderas

	Y37 rovere affumicato smoked oak
	Y38 rovere nero black oak

ripiani / shelves / étagères / Böden / estantes

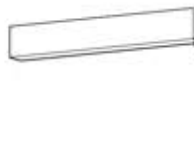

HPL

laccato
lacquered
laqué
lackiert
lacado

	Q05 bianco white
	Q16 seta silk
	Q17 corda ecru
	Q20 ghisa cast-iron
	Q14 antracite anthracite
	Q04 nero black
	Q21 bronzo bronze

essenze
woods
bois
Holzes
maderas

	Y36 rovere oak
	Y34 noce walnut
	Y37 rovere affumicato smoked oak
	Y38 rovere nero black oak

moduli interni / internal modules / modules internes / interne Module / módulos internos

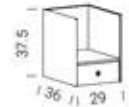
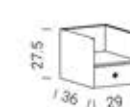
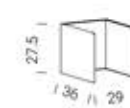

piano / top / plateau / platte / sobre

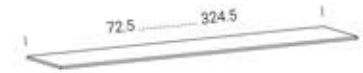

ripiani / shelves / étagères / Böden / estantes

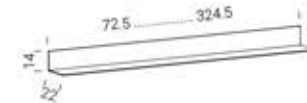
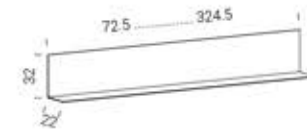

disponibili riduzioni a misura / tailor-made reduction available / disponibles réductions sur mesure
Verkleinerung nach Kundenwunsch / disponibles reducciones a medida



atelier

AT02

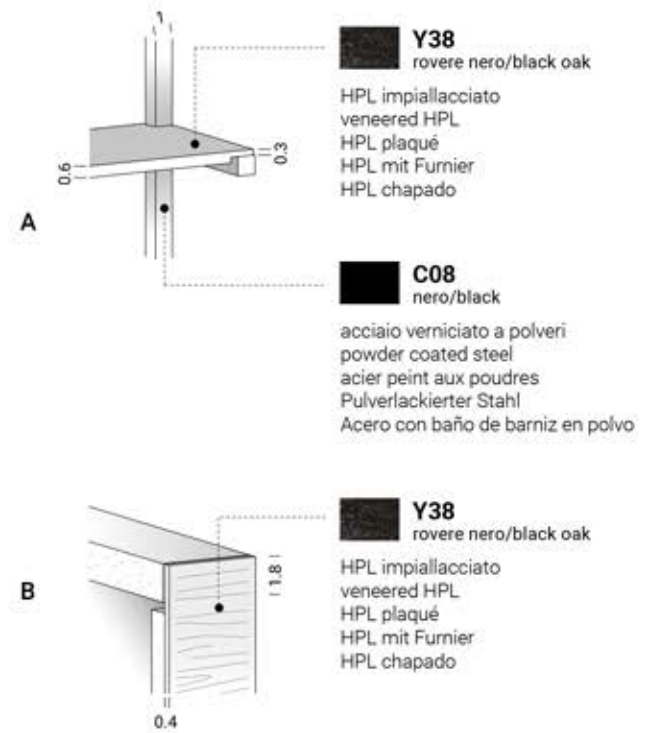
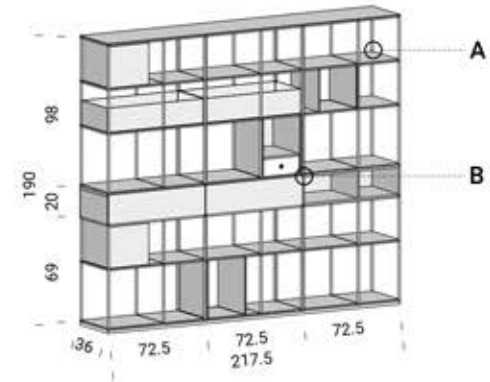

collection info
pg. 08





atelier

AT03

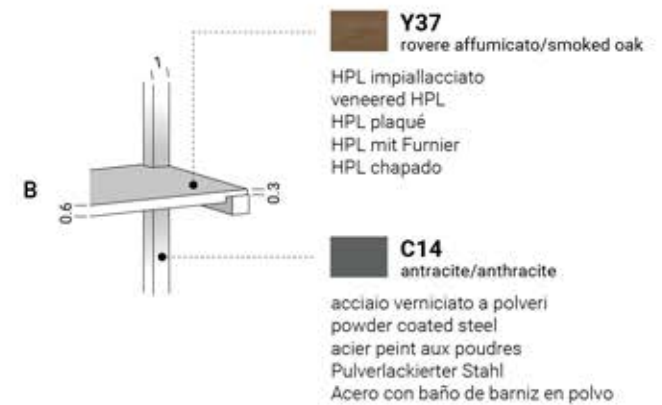
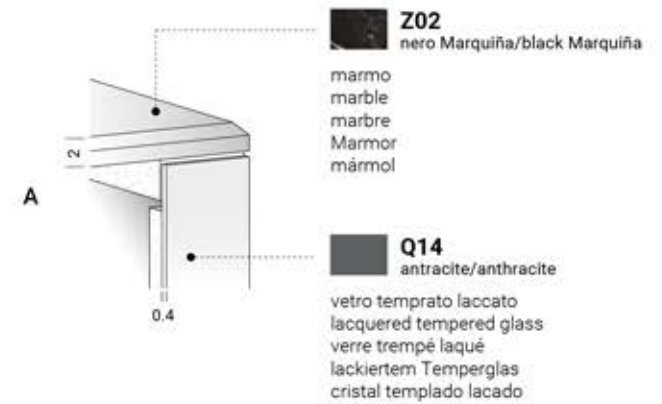
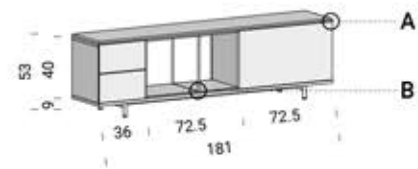

collection info
pg. 08





atelier AT01

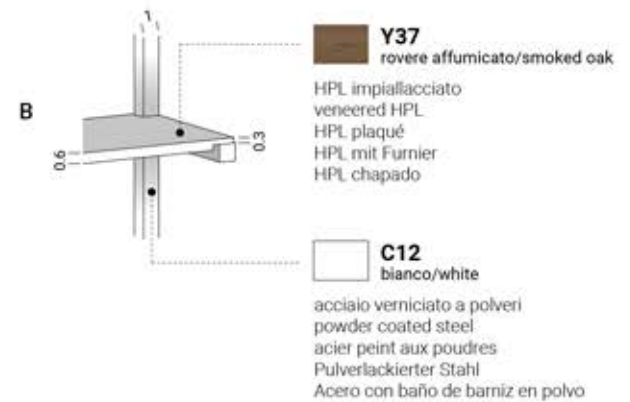
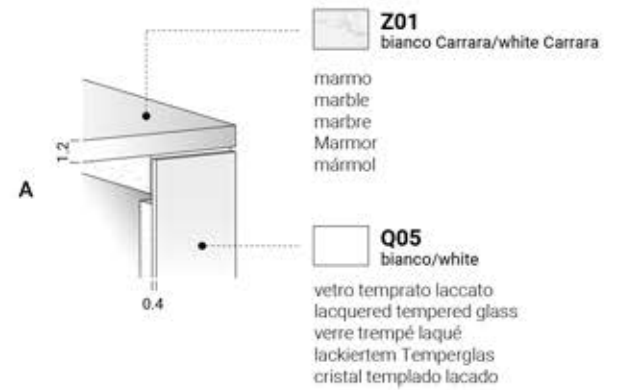
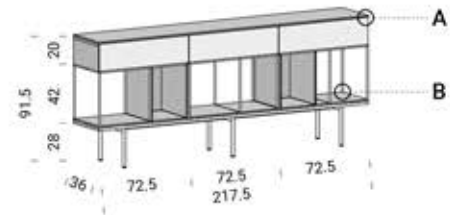

collection info
pg. 08





atelier AT04

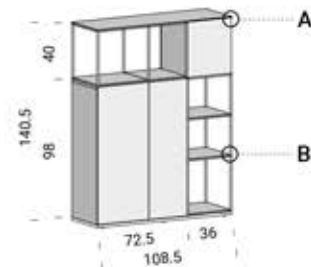

Y37
rovere affumicato/smoked oak

HPL impiallacciato
veneered HPL
HPL plaqué
HPL mit Furnier
HPL chapado

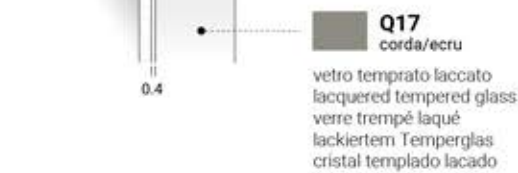

Q17
corda/ecru

vetro temprato laccato
lacquered tempered glass
verre trempé laqué
lackiertem Temperglass
cristal templado lacado



Y37
rovere affumicato/smoked oak

HPL impiallacciato
veneered HPL
HPL plaqué
HPL mit Furnier
HPL chapado

C29
bronzo/bronze

acciaio verniciato a polveri
powder coated steel
acier peint aux poudres
Pulverlackierter Stahl
Acero con baño de barniz en polvo

collection info
pg. 08





atelier

AT06

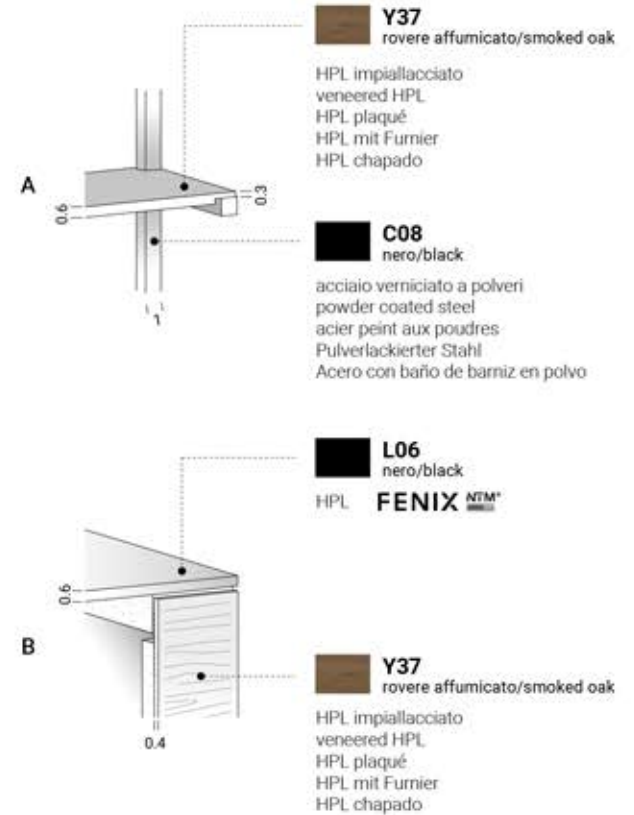
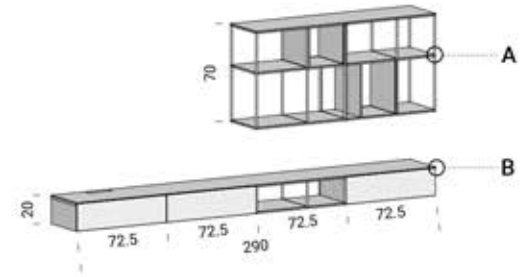

collection info
pg. 08





atelier AT05

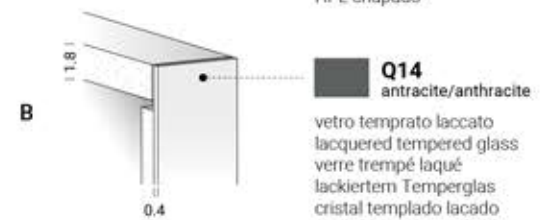
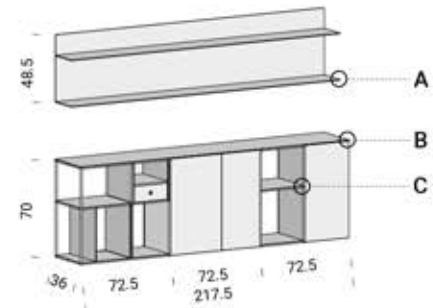

collection info
pg. 08

atelier

AT07

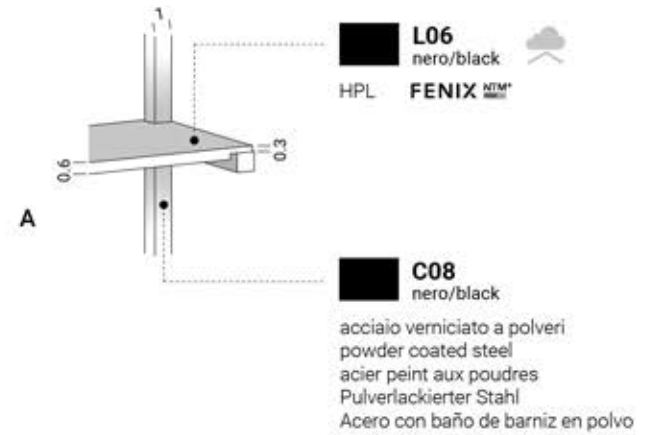
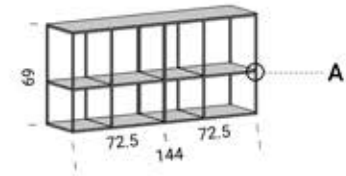

collection info
pg. 08

atelier

AT08

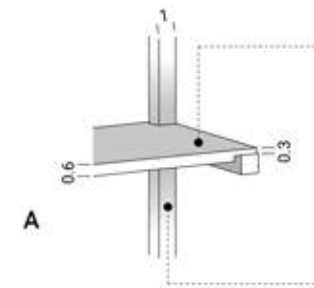
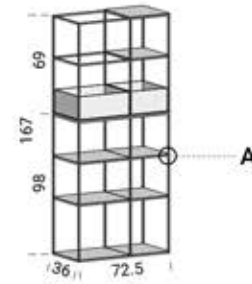

L06
nero/black

HPL **FENIX™**

C08
nero/black

acciaio verniciato a polveri
powder coated steel
acier peint aux poudres
Pulverlackierter Stahl
Acero con baño de barniz en polvo

collection info
pg. 08